

Features

Features	Code
Brake Caliper	H
Standard	W
With piston diameter 100 mm	100
Hydraulically activated	H
Spring released	F
Automatic adjustment to counter friction block wear	A
Max. clamping force 70 kN	070

Example for ordering

Brake Caliper HW 100 HFA, max. clamping force 70 kN:

HW 100 HFA - 070

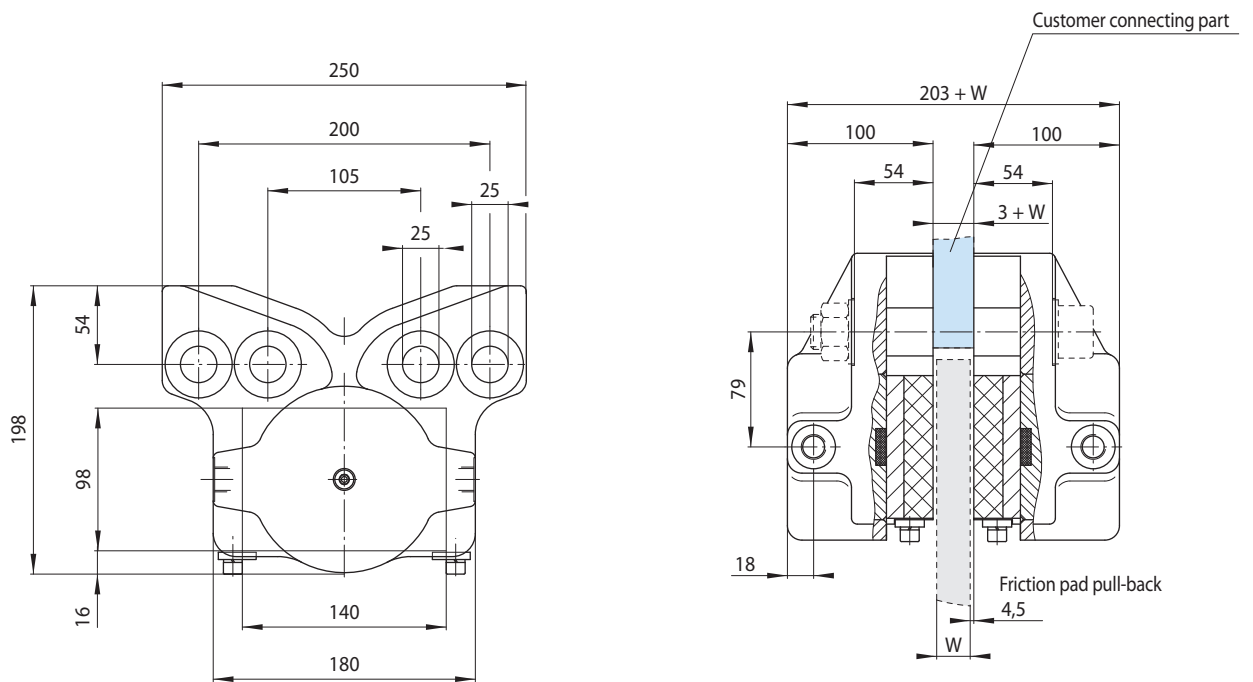

Brake Caliper HW 100 HFA

hydraulically activated – spring released

Morskate®



Mounting

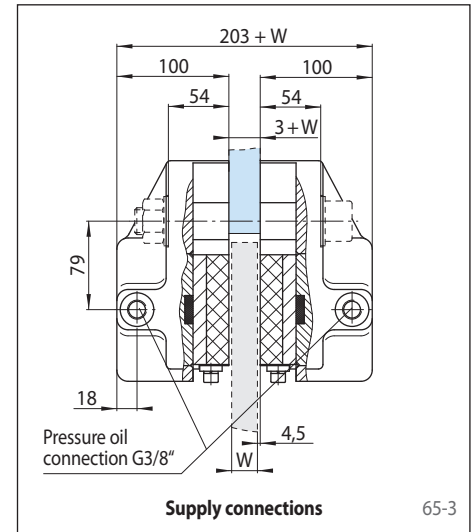
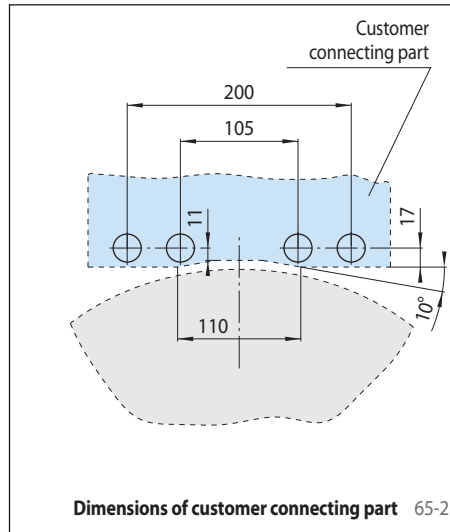
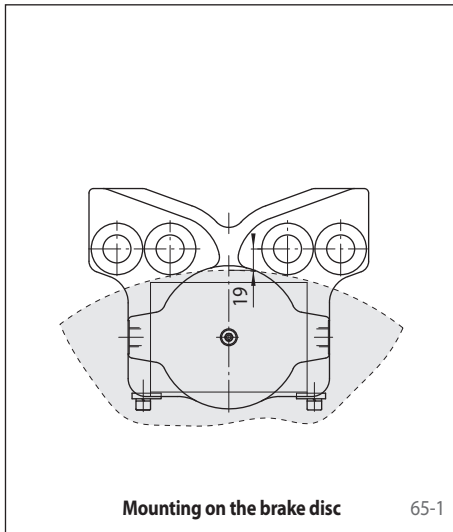

Technical Data

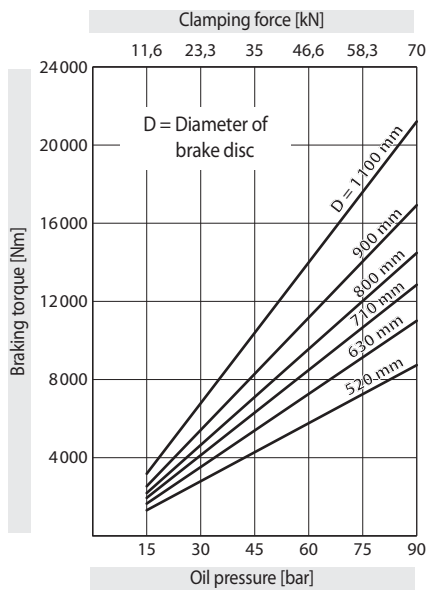

The braking torques shown in the diagram are based on a theoretical friction coefficient of 0,28.

Oil pressure: min. 5 bar
max. 90 bar

Oil volume: 71 cm³ per stroke

Weight: 30 kg

Other features

- The thickness of the customer connecting part results from the thickness of the brake disc W plus 3 mm

Any questions? Please contact us.

Morskate Aandrijvingen BV

Oosterveldsingel 47A
7558 PJ Hengelo (Ov)
The Netherlands

NL
T +31 (0)74 - 760 11 11
info@morskateaandrijvingen.nl
www.morskateaandrijvingen.nl

DE
T +49 692 - 222 34 95
info@morskateantriebstechnik.de
www.morskateantriebstechnik.de

EN
T +31 (0)74 - 760 11 11
info@morskatedrivetechnology.com
www.morskatedrivetechnology.com